

Flow switch for TRI-CLAMP® System / EHEDG certified



flow-captor 4120.1xMA S113/xx S110/xx

The flow-captor type 4120.1xMA S113/xx S110/xx is ideally suited for use in automation processes in the food industry where liquid media must be monitored. The sensor was specially designed for Tri-Clamp connections.

Application under EHEDG conditions - see additional text.

It operates according to the calorimetric measuring principle, fully electronically and without mechanically moving parts. The sensor detects the flow velocity of the medium and converts it into an electrical signal.



picture similar

- **EHEDG certified TYPE EL CLASS I** April 2019
- precise switching flow monitor
- high switching accuracy even with lower flows
- separate setting for set-point and range
- LED for output status
- display of flow condition and adjusted switch point via LED chain
- robust stainless steel design (special potting)
- **ISO 9001:2015**



Technical data		
Type	4120.1xMA S113/xx S110/xx	
Medium	water-based	
Sensor data		
Measuring range	0 - 20 cm/s to 0 - 300 cm/s continuously adjustable	
Medium temperature	-20 °C to +80 °C / -4 °F to 176 °F	
Ambient temperature	-20 °C to +70 °C / -4 °F to 158 °F	
Set-point range	approx. 15 % - 90 % of range setting	
Pressure	up to 100 bar	
Response time	2 sec. - 10 sec., according to range setting	
Linearity deviation	< 5 % ¹⁾	
Repeatability	< 2 %	
Hysteresis	approx. 10 %	
Temperature drift	< 3 % / K	
Mechanical data		
Protection class	IP67	
Housing	stainless steel AISI 303	
Sensor head	stainless steel 316L, electropolished	
Flange dimensions	D50.5 mm or D64 mm	
Electrical connection	4-pin M12 plug	
Connection cable (optional)	2 m PUR cable type 4940, 3 x 0.34 mm ² with 4-pin M12 coupling	
Electrical data (Electronic unit)		
Operating voltage	18 to 30 VDC, incl. residual ripple	
Current consumption	max. 150 mA (pulsed)	
Power consumption	approx. 1 W	
Switching current	≤ 400 mA	
Circuit protection	reverse polarity, short circuit and overload	
Voltage drop	< 2.5 V at max. load	
Initial operation	approx. 10 sec. after connection of power	
Elektrischer Ausgang		
	4120.12MA	4120.13MA
Switching condition with flow < switching point	energized, switched	currentless, not switched
LED	off	off
Switching condition with flow > switching point	currentless, not switched	energized, switched
LED	green	green

¹⁾ relate to water



Connection diagram:

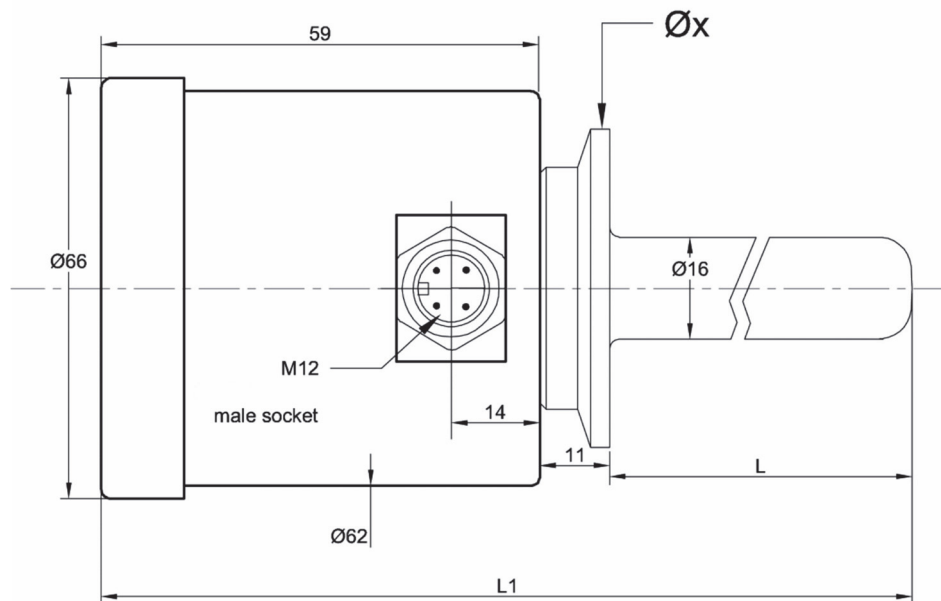
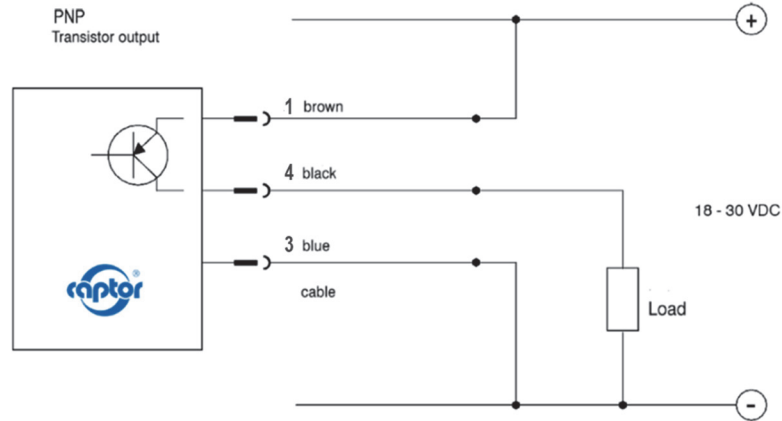

	S113/xx	S110/xx	
Part - No.	Dx	L	L1
0703138	50,5	47,5	117,5
0703246	50,5	67,0	137,0
	64,0	47,5	117,5

Zusatztext für die Anwendung unter EHEDG - Bedingungen
Additional text for the application under EHEDG conditions

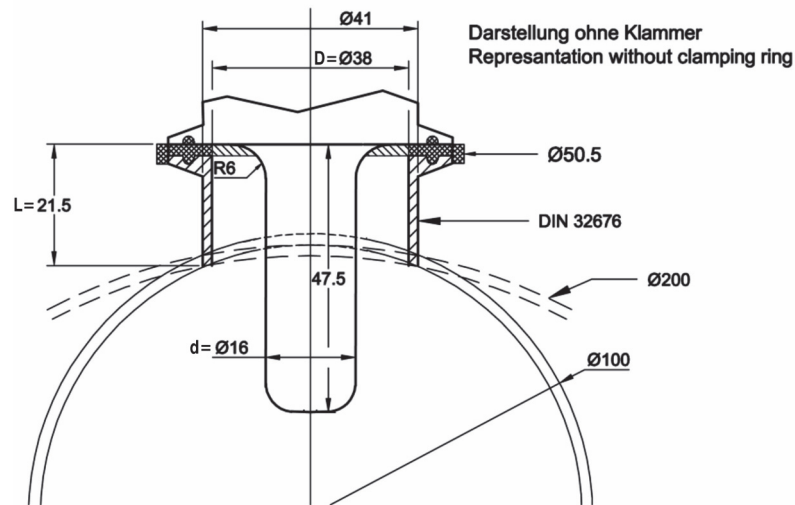

DIN Klemmstutzen, kurz, DIN 32676 (DN 40 (siehe Zeichnung) oder DN 50)
DIN Clamp ferrule, short, DIN 32676 (DN 40 (see drawing) or DN 50)

Hinweis für den Einsatz des Sensors nach EHEDG

(European Hygienic Engineering and Design Group)

Der Sensor ist EHEDG zertifiziert. Diese Zertifizierung gilt NUR bei Verwendung von EHEDG zertifizierten Adaptern und Dichtungen.

Zur Vermeidung von Toträumen nur DIN Klemmstutzen, kurz (DN 40 oder DN 50), DIN 32676, verwenden.

Bei Verwendung von Prozessanschlüssen anderer Hersteller, ist der Einbauort und die Einbauumgebung zu beachten. Es ist auf eine EHEDG-konforme Einbindung in das System zu achten, dabei gilt folgende Bedingung: $L < (D-d)$! Tri-Clamp erfüllt nur mit Combifit Dichtungen die EHEDG Zulassung (verfügbar auf der EHEDG Webseite www.ehedg.org).

Wartung und Reinigung

Vor dem Einbau und/oder bei der Wartung des Systems, ist der Sensorkopf, der Einbauadapter und die Dichtung mit geeigneten Methoden zu reinigen, damit die Dichtigkeit und Totraumfreiheit weiterhin gewährleistet ist. Der Sensor ist CIP (cleaning in place) fähig und kann ohne Demontage zusammen mit der Rohrleitung gereinigt werden.

Note for the use of the sensor according to EHEDG

(European Hygienic Engineering and Design Group)

The sensor is EHEDG certified. This certification ONLY applies when using EHEDG certified adapters and gaskets.

To avoid dead legs only use DIN clamp ferrule, short (DN 40 or DN 50), DIN 32676.

When using process connections from other manufacturers, the installation location and the installation environment must be observed. EHEDG-compliant integration into the system must be ensured! The following condition applies: $L < (D-d)$.

Tri-Clamp meets the EHEDG approval only with Combifit seals (available on the EHEDG website www.ehedg.org).

Maintenance and cleaning

Before installing and/or maintaining the system, the sensor head, the installation adapter and the seal must be cleaned using approved methods to ensure that the system remains leakproof and free of dead space. The sensor is CIP (cleaning in place) capable and can be cleaned together with the piping without disassembly.