

Installation and Operation Instructions vent-captor type 3202.30 (3205.30)



Please read carefully: No liability for any damage resulting from improper handling of the sensor.

4.0 Adjustment Procedure

4.1 Zero point adjustment in stationary medium: Adjust potentiometer P2 after **5 minutes** so that $I_a = 4 \text{ mA}$.

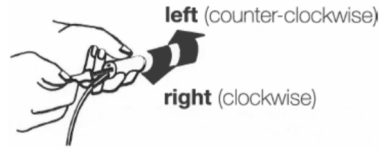

i.e. if $I_a > 4 \text{ mA}$ turn pot. P2 slowly to the left
if $I_a < 4 \text{ mA}$ turn pot. P2 slowly to the right.

4.2 Measuring range setting at maximum flow, which corresponds to 20 mA. After at least 3 minutes of flow, set potentiometer P1 so that $I_a = 20 \text{ mA}$. If $I_a > 20 \text{ mA}$, LED lights red; turn P1 slowly to the right; if $I_a < 20 \text{ mA}$, LED lights green. Turn P1 slowly to the left.

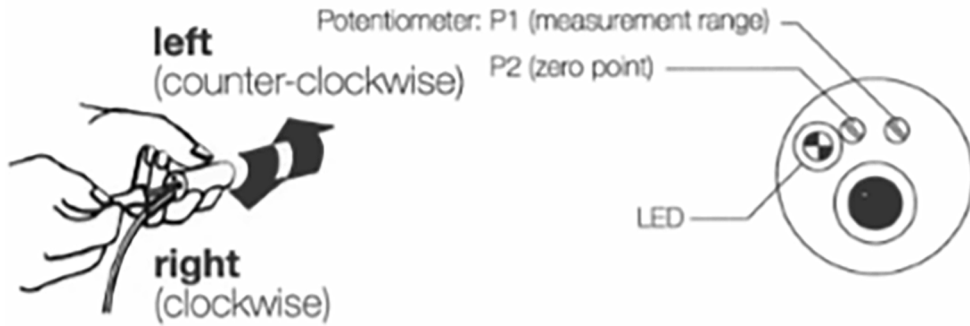

4.3 Check Zero Point and Range

Check zero flow adjustment and measuring range adjustment as described in point 4.1 and 4.2 and make corrections if necessary.

4.4 Green LED signals current output range up to 20 mA. If the measuring range is exceeded ($I_a > 20 \text{ mA}$), the LED shines red.

Installation and Operation Instructions vent-captor type 3202.30 (3205.30)



Please read carefully: No liability for any damage resulting from improper handling of the sensor.



With flange (atmospheric pressure)

Type 3202.30 with flange

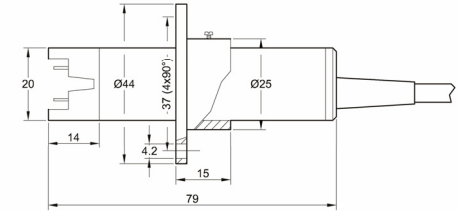

with PG21 (up to max. 1 bar)

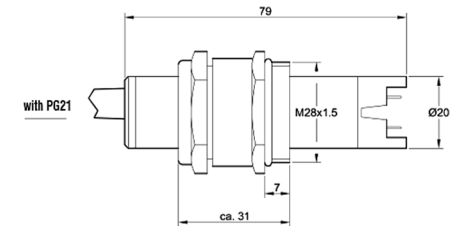

with union nut in stainless steel casing
(from 1 bar to max. 10 bar) 3205.30

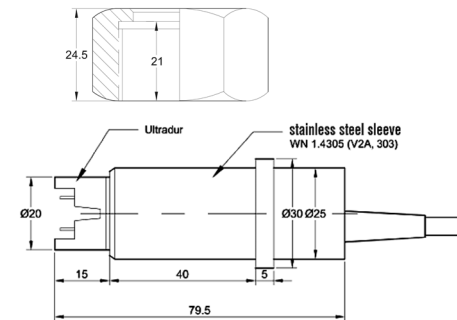

Type 3205.30: Techn. Data as 3202.30
max. pressure 10 bar, installation with union nut
G 1" A, SW 37 mm, DIN 259, ISO 228
mass approx. 200 g without nut

weber

weber

Installation and Operation Instructions vent-captor type 3202.30 (3205.30)



Please read carefully: No liability for any damage resulting from improper handling of the sensor.

1.0 vent-captor type Number

- 1.1 Type 3202.30: type number printed on housing
- 1.2 Type 3205.30: type number indicated on adhesive label
- 1.3 Measurement range: stamped on cable (e.g. 20 m/s)
- 1.4 Identification of special version: stamped on cable (e.g. S100)

2.0 Installation Instructions

2.1 Installation Depth

Depends on pipe (duct) diameter but min. 15 mm

2.2 Orientation

Position the ceramic sensor elements so that they are parallel to the direction of flow, as illustrated below.

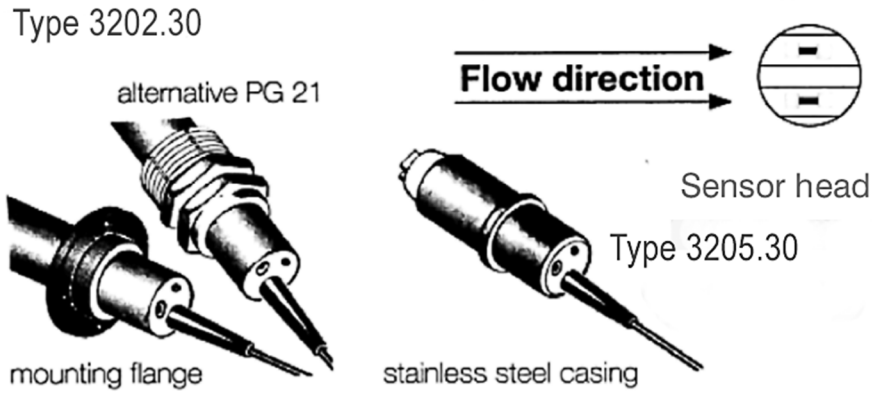

2.3 Installation Site

Optimal installation is with a straight free run of 5-7 x ID diameter upstream and 3-5 x ID diameter downstream of the vent-captor.

2.4 Mounting the 3202.30 with flange

Screw on the mounting flange and position the vent-captor at the desired depth in the pipe and secure it with the side screw. Instead of the flange, a PG21 made of plastic or metal can be used.

weber

Installation and Operation Instructions vent-captor type 3202.30 (3205.30)



Please read carefully: No liability for any damage resulting from improper handling of the sensor.

2.5 Installation of type 3205.30

Slide the O-ring over the metal body up to the metal collar. Then insert the vent-captor into the pre-assembled 1" fitting. With the supplied union nut, the vent-captor is screwed into the fitting. The fitting can be ordered separately. The length of the fitting must be so dimensioned that the correct immersion depth of the sensor is ensured.

2.6 Powering Up

Connect the vent-captor to 24 VDC as in connection diagram and wait approx. 5 minutes before starting the adjustment

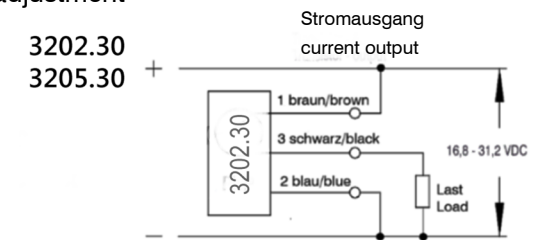

3.0 Initial State

- 3.1 The zero point potentiometer P2 is factory set to approx. 4 mA.
- 3.2 The measuring range potentiometer is at the right stop, i.e. max. measuring range (> nominal range).
- 3.3 With factory range setting (according to customer specification), both potentiometers are sealed. The sensors are adjusted under our test channel conditions. Output signal deviations - with other, customer conditions - cannot be excluded.

Attention: 18-turn potentiometers have no mechanical limit stop.

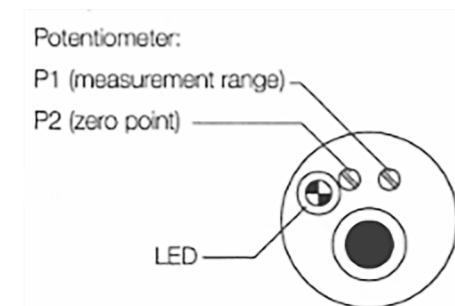

weber