

flow monitor for gaseous media



vent-captor 3202.0x

The vent-captor type 3202.0x is an air flow monitor that is used where air and other gases in an automation process need to be monitored.

This compact, electronic sensor works according to the calorimetric measuring principle and without mechanically moving parts. It detects the flow velocity of the medium and converts it into an electrical signal.

- small compact unit
- adjustable switching point
- temperature independent
- robust construction (fully resin encapsulated)
- **ISO 9001:2015** certified production





Technical data	
Type	3202.0x
Medium	gaseous (aggressive media on request)
Sensor data*1	
Measuring range	0.5 to 50 m/s
Adjustment	continuously adjustable
Hysteresis	approx. 0.4 m/s
Display output status	LED red / green
Repeatability	< 3 %
Medium temperature	-20 °C to +70 °C
Ambient temperature	-20 °C to +70 °C
Pressure	with flange: atmospheric, with PG21: max. 1 bar
Temperature drift	< 0.3 % / K
Mechanical data	
Protection class	IP 64
Material sensor probe	ceramic with overglaze
Material housing	Ultradur (PBTP)
Electrical connection	2 m moulded oilflex cable 3 x 0.5 mm ²
Housing dimensions	see drawing no. K72034
Electrical data	
Operating voltage	24 VDC (16.8 - 31.2 VDC)
Switching current	max. 400 mA
Power consumption	40 - 140 mA (max. flow)
Protection circuit	reverse polarity, short circuits and overload protection (ready for operation after correcting the short circuit)
Starting override time	approx. 25 s
Electrical output without flow	3202.00 NPN n.c. 3202.02 PNP n.c. 3202.01 NPN n.o. 3202.03 PNP n.o.

*1 all data related to medium air

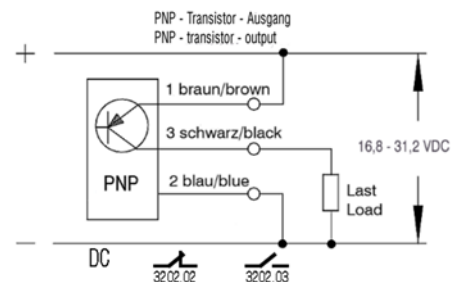
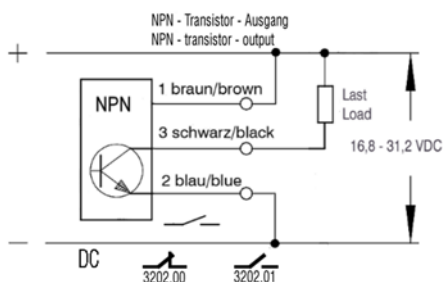
connection diagram:

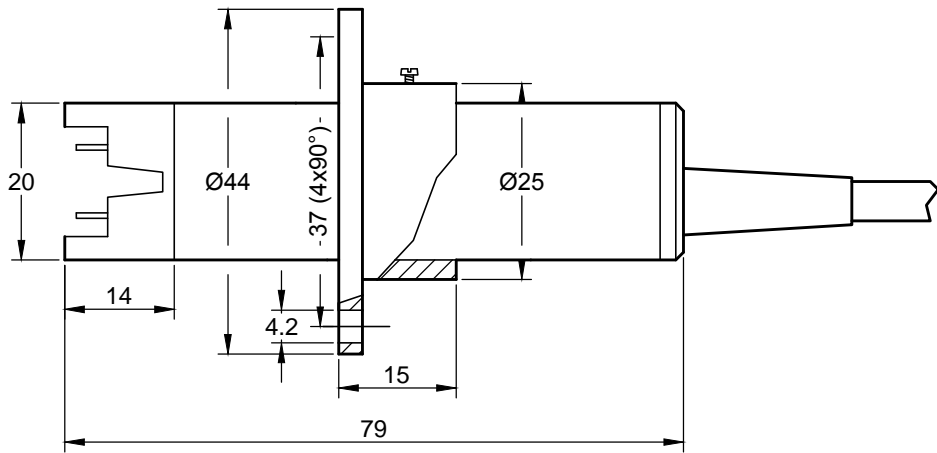



				vent captor 3202.xx mit Montageflansch with mounting flange		Maßstab	M 1 : 1	weber Sensors GmbH 25377 Kollmar, Strohdreich 32 Tel.: +49 4128 591 - Fax: - 593 www.captor.de info@captor.de	
neu in ACad	25.10.17	Vog	AD			Gerät	3202.xx		
neuer Rahmen	27.03.95	Hue	AC			File - Nr.:	K72034		
14 / 79	10.05.93	Wip	AB						
Aend.	Datum	Name	Rev	entw.	gez. Hüttmann	23.02.93	gepr.	Blatt 1 - 1	